

Wanco™ Light Towers



WANCO™ The Industry leader.

800-972-0755
www.wanco.com



**Working late?
Light up your job site with Wanco™ Light Towers.**

Not just another light tower, Wanco Light Towers use state-of-the-art technology to achieve the most efficient illumination, shining a uniform light pattern across the entire job site — up to 7.5 acres at 0.5 footcandles.

Other advancements include a choice of low-speed engines that provide trouble-free diesel performance and greater longevity, and unsurpassed engine accessibility via a maintenance panel that lifts completely out of the way.

With a reputation for service and integrity, Wanco products feature superb functionality, unique features, versatility and dependability.

Light fixtures

The Wanco Light Tower's high-output fixtures feature a high-intensity parabolic reflector that increases illumination and creates a brighter, more uniform light pattern. The result is greater visibility and improved safety for workers. For fast job-site setup and less downtime, each light fixture can be aimed independently without the use of tools—and the fixtures stay in place once positioned.

Tower

The telescoping tower assembly is double-reinforced for stability and safety, while nylon bushings separate and align each section, ensuring smooth operation. Two winches raise and extend the mast, with both power- and hand-operated winches available. The light tower mast rotates 360 degrees, and the lights can be operated at any height, eliminating the need to move the trailer frequently.

Power system

The power system includes a choice of rugged, low-RPM diesel engines and high-quality four-pole generators. A 30-gallon fuel tank provides extended run times of 60 to 70 hours between refueling, depending on environmental influences. The rugged, translucent polyethylene fuel tank is rupture resistant and offers an instant view of fuel level, eliminating the need for a fuel gauge.

Serviceability

Wanco has created a unique innovation that greatly improves serviceability. For complete access to the engine, generator and electrical components, the Wanco Light Tower features a hinged top panel that rises with the mast when maintenance is required. No other light tower makes engine access this easy. The gull-wing side doors may be opened while the maintenance panel is raised, further enhancing access.



Hinged top panel opens fully. The light tower mast attaches to the panel for maintenance and raises the panel using the drawbar winch.



Engine and components are easily accessible with top panel up. Crossbar can be removed and side doors can be opened with panel raised.

Specifications

Physical

Dimensions in inches (mm)

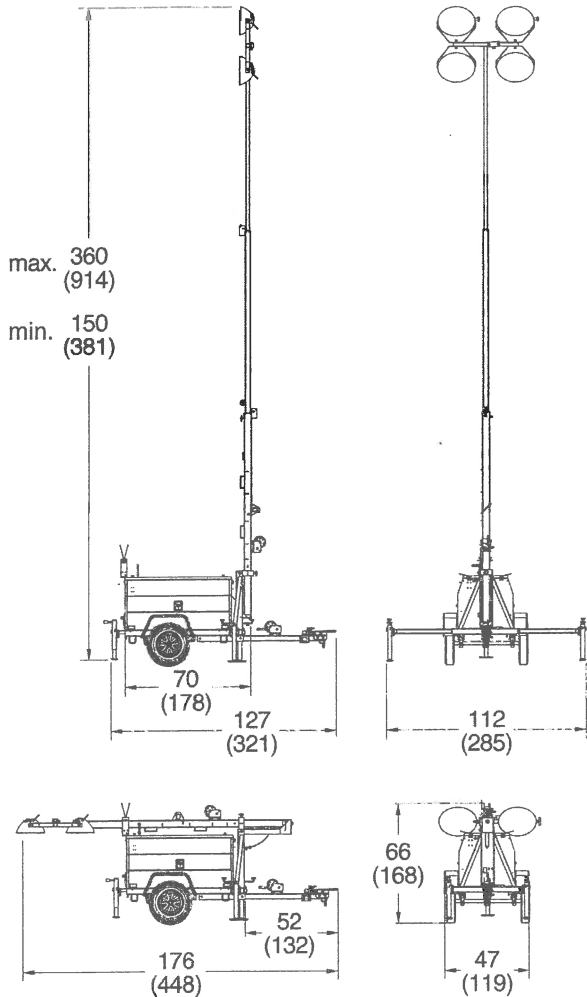

Operating weight	1800 lbs. (815kg)
Shipping weight	1580 lbs. (717kg)
Tires	ST175/80D13
Low hitch	Combo-type for 2-inch ball and 3-inch pintle hook

Lights

Wattage	1000 watts per lamp, from one to four lamps
Luminosity	0.5 fc (5.4 lm/m ²)
Coverage	Up to 7.5 acres (30,400 m ²)

Output power

Output	6 kW
Voltage	120 V or 240 V*
Amperage	50 A @ 120 V 25 A @ 240 V
Frequency	60 Hz or 50 Hz*
Power draw	1.0 kW
Voltage regulation	±5%, no load to full load

Power system

Engine type	3-cylinder, 4-cycle, liquid-cooled diesel
Engine speed	1800 rpm
Generator type	Brushless
Generator insulation	H
Battery	12 V dc, 550 CCA
Maximum power output	12.1 or 13.6 hp (9 or 10 kW)*
Displacement	56 or 68 cu. in. (916 or 1123cm ³)*
Sound level at maximum load	71 dB at 23 feet (7m)
Fuel tank capacity	30 gal. (114L)
Fuel consumption	0.44 gal./hr. (1.67L/h)
Runtime before refueling	60 to 70 hrs., approx.

*Depending on model

Functional

Steel enclosure protects components from the elements. Enclosure is powder-coated, lockable, and weather-resistant.

Two outriggers and four leveling jacks provide stability.

Control panel features elapsed hour meter, 120-volt GFCI receptacle for powering external equipment, and circuit breakers for on/off functionality and protection.

Diesel engine includes glow-plug preheat system for increased service life and improved cold-weather starting.

Automatic engine shutdown system protects engine from damage due to low oil pressure and high coolant temperature.

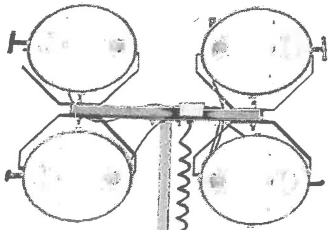

Now get Wanco ingenuity in a portable light tower.

For 25 years Wanco has been building light towers for major North American companies. Today, we apply our experience, engineering expertise and dedication to quality to the new Wanco Light Tower, with innovation the industry has never seen.

Portable light towers are ideal for wide-area outdoor lighting in a variety of construction, commercial and special event applications. The Wanco Light Tower features four 1000-watt light fixtures atop a 30-foot variable-height mast.

- **High-output light fixtures** provide super-bright illumination and uniform light coverage
- **Double-reinforced tower assembly** with nylon spacer bushings combines stability and safety with smooth operation
- **Multiple low-speed engine options** offer trouble-free diesel performance and greater longevity
- **Unobstructed engine accessibility** with hinged top panel, provides full access to engine, generator and electrical components

